



NISSAN

NP300  
HARDBODY



**PROVEN**

# HARD BODY



# PROVEN DURABILITY AFRICAN BORN, AFRICAN HARDENED

Tested in the most unforgiving conditions Africa has to offer, the NISSAN NP300 HARDBODY has proven over the years that it's made to last. Specifically engineered for harsh environments, all NP300 HARDBODY models incorporate a heavy duty axle with reinforced chassis and suspension to absorb the impact of the toughest terrain.

The NISSAN NP300 HARDBODY has a backbone to match, too. A full-length, closed section ladder-type frame with high-tensile-strength steel – stronger than conventional steel – in strategic areas ensures improved structural rigidity. This means increased torsional stiffness, helping to deliver enhanced performance on-and off-road, whatever the load. Further proof that the NISSAN NP300 HARDBODY is the pickup built to tackle any challenge Africa has to offer.



4WD double cab high grade



2WD single cab mid grade

# PROVEN PERFORMANCE BUILT FOR THE LONG HAUL, DESIGNED TO PERFORM



## ENGINE

Nissan diesel engines have built an enviable reputation for clean firing, smoother acceleration and drivability, resulting in impressive fuel efficiency with reduced emissions. The result is a quieter ride with less vibration, wear and tear and an overall decrease in maintenance costs. And the eco-friendly oil cartridges can be completely incinerated after use, making our engines as environmentally responsible as they are hard working.

The NISSAN NP300 HARDBODY's intercooled 2.5 litre common rail turbo diesel engine balances toughness and power with excellent fuel efficiency, using the combination of turbo and intercooler to deliver 98kW (131.4hp) of power and 304Nm (30.7 kg-m) of torque.

## DRIVE TRAIN

Clean and easy shift changes are provided by the 5-speed manual transmission, and a braking systems load-sensing valve increases brake power to the rear when moving large loads, ensuring the NP300 HARDBODY makes light work of the toughest jobs.

Engaging 4WD locks the transfer case in a 50/50 torque split for maximum traction from front and rear axles. Auto locking hubs come standard on the NISSAN NP300 HARDBODY 4WD models. When not in use, the hubs are automatically released, improving fuel economy.

## LIMITED SLIP DIFFERENTIAL

4WD models come standard with a Limited Slip Differential which automatically transfers torque to the non-slipping drive wheel, allowing you to power out of virtually any situation. And unlike diff lock, it won't lead to expensive breakages due to negligence and can work at speed.

# PROVEN DESIGN MADE FOR BUSINESS

## INSIDE AND OUT, THE NISSAN NP300 HARDBODY IS DESIGNED TO KEEP YOUR BUSINESS MOVING IN THE RIGHT DIRECTION

### RUGGED EXTERIOR

The NISSAN NP300 HARDBODY's build quality and robustness extends to the exterior finishes too: developed and tested by firing diamond chips at the paintwork ensures maximum protection from flying gravel or stone. In addition, the all-round E-coat anti-rust treatment means that it can cope in extreme damp or humid conditions.

The pickup's masculine presence is enhanced in higher grade models with a roll bar, side steps, roof rail and an aluminium rear step bumper, while workhorse models come standard with a guard frame for extra cab protection when carrying loads. Add the reinforced load box, extra-strength tailgate chains, double-walled tailgate and rear side panels and sturdy cargo hooks, and it becomes clear that the NP300 HARDBODY really means business.

All diesel models feature a bonnet scoop that increases airflow into the turbo charger's intercooler, and hints at the formidable power beneath the hood. The long travel suspension with 15" steel wheels on the 2WD Single Cab, and 16" alloy wheels on all other models, allows for excellent ground clearance and the confidence to handle almost any African terrain.



### VERSATILE INTERIOR

Comfort and functionality on all models are provided by tilt adjustable and power steering, and sliding front seats make getting in as easy as getting out.

A range of additional features are available depending on the model and grade: lockable glove box and door pocket with drinks holder, air-conditioner, radio with CD player, centre console with cup holders and power windows.

### PROVEN PARTNERSHIP

The NISSAN NP300 HARDBODY remains the ideal choice of business partner in the commercial sector. Its dependable heritage has been built on well-proven mechanical underpinnings while fulfilling – and often going beyond – the essential functional systems requirements of today's business operations.

With a proud history of solid durability and reliability, together with strong after-sales support, skilled technicians and readily available parts, downtime is reduced to a minimum. This, together with the economical total cost of ownership, ensures your business stays firmly where it belongs – on the road.

# NP300 HARDBODY



# PROVEN IRONCLAD PROTECTION

THE NISSAN NP300 HARDBODY MAKES SAFETY AND SECURITY A PRIORITY



## SAFETY

A steel reinforced chassis provides strength and absorbs the force from the front, while crease folds minimise impact in the cabin and side door intrusion bars add further protection to occupants in the event of an accident. Add driver and passenger airbags, in conjunction with the 3-point ELR seatbelt, and you are assured of the maximum protection all round.

For greater handling and control, the NP300 HARDBODY comes with fade resistant shock absorbers, ventilated front discs and a rugged double wishbone and independent suspension with telescopic shock absorbers, while the Anti-lock Braking System optimises braking performance.

With higher ground clearance and halogen headlamps for all-round visibility, you can be confident that both your people and your cargo are in safe hands.

## SECURITY

The NISSAN NP300 HARDBODY makes security a priority. Standard in top of the range models are remote, keyless entry, central locking and child locks. And throughout the range, immobiliser, personally coded ignition key and fuel tank cap key are standard. For more detailed information on features, please see the specifications table.





# PROVEN TAILORED TO YOUR REQUIREMENTS

## ALL THE EXTRAS YOU NEED FOR THE PERFECT FIT

You know what you like. And with Nissan approved accessories you can customise your NP300 HARDBODY to perfectly fit your needs, whether it's functional style you're looking for or enhanced utilitarian capability.

Speak to your Nissan dealer for more information on the full range.

Some accessories are not compatible with all model grades.

Accessories available include:

- Tonneau Cover
- Towing Kit
- Canopy
- Loadbox rubberising
- Spare wheel locks
- Sports Bars
- Side Steps
- Bonnet and Headlamp guards
- Carpet sets
- Wraparound bushbar
- Nudgebar





# COLOUR



Arctic White - QM1 (S)



Bright Silver - KY0 (M)



Thermal Gold - K32 (M)



Infinite Black - KH3 (S)\*



Solid Red - AX6 (S)\*



Claret Red - AY4 (M)

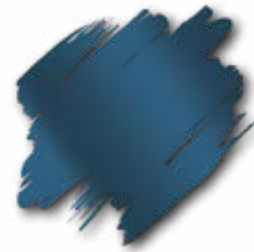

Starling Blue - B16 (M)

\*Special Order  
(S) Solid  
(M) Metallic

## Nissan's commitment to quality

To provide all customers with a consistently high level of quality, Nissan applies the same standards worldwide, to ensure that all Nissan owners enjoy peace of mind for the lifespan of their vehicles. The approach is based on quality from the customer's perspective on three key elements. First, the expectation of a smooth driving experience with complete peace of mind. Second, the intangible appeal of a vehicle, its power to captivate and excite, with features that capture attention and imagination. Third, the level of attentiveness and service during the sales process, and long after the sale is concluded.

# TRIM

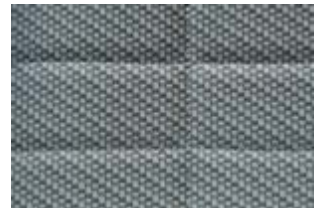

PVC

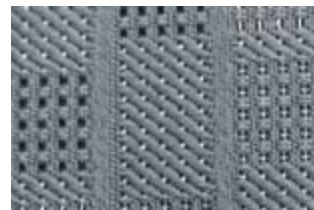

Woven fabric



Fabric with leather insert

# DIMENSIONS

## SINGLE CAB

Unit: mm

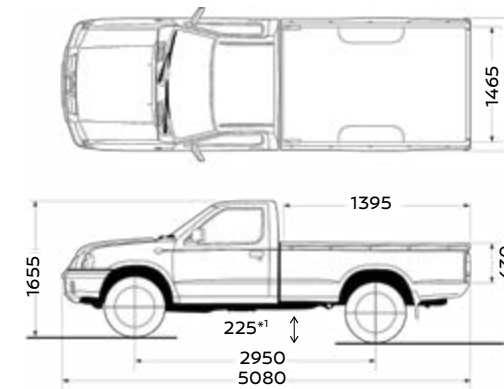

\*1 2WD 205mm

## DOUBLE CAB

Unit: mm

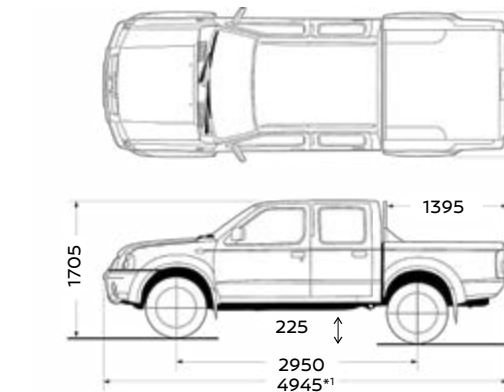

\*1 STD Grade 5080mm \*3 STD Grade 1465mm

\*2 STD Grade 1690mm \*4 STD Grade 430mm

# PEACE OF MIND

## OUR PROMISE TO YOU

At Nissan we keep our promises and take care of our family. Servicing and repairing your Nissan at an authorised Nissan dealership is the way to go. Our Nissan technicians are highly trained specialists that know your Nissan better than anyone. They will use Genuine Nissan Parts, Genuine Nissan Accessories to ensure quality, reliability and to keep your vehicle performing to optimum standards. Nissan aims to keep you and your vehicle on the road with total peace of mind - for as long as possible.

**THIS IS A NISSAN AFTERSALES PROMISE.**

# NISSAN

## AFTERSALES

OUR PROMISE. YOUR EXPERIENCE

Model	Single Cab		Double Cab			
	2.5D SC	2.5D 4X4 SC	2.5D HIGH DC	2.5D 4X4 DC	2.5D HIGH 4X4 DC	
Drivetrain and fuel type		2WD Diesel	4WD Diesel	2WD Diesel	4WD Diesel	4WD Diesel
Grade		Standard	Standard	High	Standard	High
<b>ENGINE</b>						
Engine code		YD25	YD25	YD25	YD25	YD25
Displacement	cm <sup>3</sup>	2488	2488	2488	2488	2488
Max power output	kw/rpm	98/3600	98/3600	98/3600	98/3600	98/3600
Max torque	Nm/rpm	304/2000	304/2000	304/2000	304/2000	304/2000
Type		Intercooler turbo diesel, 4-cyl. In-line, DOHC	Intercooler turbo diesel, 4-cyl. In-line, DOHC	Intercooler turbo diesel, 4-cyl. In-line, DOHC	Intercooler turbo diesel, 4-cyl. In-line, DOHC	Intercooler turbo diesel, 4-cyl. In-line, DOHC
Compression ratio		16.5:1	16.5:1	16.5:1	16.5:1	16.5:1
<b>TRANSMISSION</b>						
Transmission		5-Speed Manual	5-Speed Manual	5-Speed Manual	5-Speed Manual	5-Speed Manual
Gear ratios	1st	3,580	3,580	3,580	3,580	3,580
	2nd	2,077	2,077	2,077	2,077	2,077
	3rd	1,360	1,360	1,360	1,360	1,360
	4th	1,000	1,000	1,000	1,000	1,000
	5th	0,760	0,760	0,760	0,760	0,760
Final drive Ratio		3,900	3,700	3,700	3,700	3,700
Limited Slip Differential (LSD)		-	Standard	-	Standard	Standard
<b>HANDLING</b>						
Brakes	Front	Disc	Disc	Disc	Disc	Disc
	Rear	Drum	Drum	Drum	Drum	Drum
Anti-lock Braking System (ABS)		Standard	Standard	Standard	Standard	Standard
Suspension	Front	Independent double wishbone torsion bar with telescopic shock absorbers	Independent double wishbone torsion bar with telescopic shock absorbers	Independent double wishbone torsion bar with telescopic shock absorbers	Independent double wishbone torsion bar with telescopic shock absorbers	Independent double wishbone torsion bar with telescopic shock absorbers
	Rear	Solid axle, leaf spring with telescopic shock absorbers	Solid axle, leaf spring with telescopic shock absorbers	Solid axle, leaf spring with telescopic shock absorbers	Solid axle, leaf spring with telescopic shock absorbers	Solid axle, leaf spring with telescopic shock absorbers
Power steering		Standard	Standard	Standard	Standard	Standard
Height adjustment steering wheel	tilt	Standard	Standard	Standard	Standard	Standard
Turning circle	tyres, m	5,9	6,3	5,9	6,3	6,3
	body, m	6,4	6,7	6,4	6,7	6,7
Auto free running hub		-	Standard	-	Standard	Standard
<b>LOAD AND DIMENSIONS</b>						
Fuel tank capacity	litres	75	75	75	75	75
Tyre size		215/R15	245R16	245R16	245R16	245R16
Wheel size		15"	16"	16"	16"	16"
Wheel finish		Steel	Steel	Alloy	Steel	Alloy
Gross Vehicle Mass	kg	2730	2740	2730	2740	2740
Gross Combination Mass	kg	3730	4240	4130	4140	5740
Tare	kg	1563	1728	1731	1816	1844
Load Capacity (GVM - Tare)	kg	1167	1012	896	924	896
Towing capacity: Unbraked	kg	750	750	750	750	750
Towing capacity: Trailer with overrun brake	kg	1400	1400	1400	1400	1400

Model	Single Cab		Double Cab			
	2.5D SC	2.5D 4X4 SC	2.5D HIGH DC	2.5D 4X4 DC	2.5D HIGH 4X4 DC	
<b>LOAD AND DIMENSIONS CONTINUED</b>						
Ground clearance	mm	205	225	225	225	225
Overall Length	mm	5080	5080	4945	5080	4945
Width	mm	1690	1690	1820	1690	1820
Height	mm	1655	1655	1705	1705	1705
Wheelbase	mm	2950	2950	2950	2950	2950
Front track	mm	1395	1395	1395	1395	1395
Rear track	mm	1390	1390	1390	1390	1390
Loadbox length	mm	1395	1395	1395	1395	1395
Loadbox width	mm	1465	1465	1390	1465	1390
Loadbox depth	mm	430	430	435	430	435
<b>SAFETY</b>						
Driver and passenger airbags		Standard	Standard	Standard	Standard	Standard
Seat belt (front)		3-point inertia reel	3-point inertia reel	3-point inertia reel	3-point inertia reel	3-point inertia reel
Side impact protection		Door guard bar	Door guard bar	Door guard bar	Door guard bar	Door guard bar
Headlamps		Halogen	Halogen	Halogen	Halogen	Halogen
Fog lamps		-	-	Standard	-	Standard
Central locking (remote control)		-	-	Standard	-	Standard
Anti-theft device (immobilizer)		-	-	Standard	-	Standard
<b>COMFORT AND CONVENIENCE</b>						
Air conditioner		Standard	Standard	Standard	Standard	Standard
Power windows		-	-	Standard	-	Standard
Mirror		Black, manual adjustment	Black, manual adjustment	Chrome, power adjustment	Black, manual adjustment	Chrome, power adjustment
Glove box		Standard	Standard	Standard	Standard	Standard
Centre console		-	-	Standard	-	Standard
Door pockets		Standard	Standard	Standard	Standard	Standard
Seat type (front seats)		Bench	Bench	Separate Bucket Seat	Separate Bucket Seat	Separate Bucket Seat
Carpet floor cover		Vinyl	Carpet	Carpet	Carpet	Carpet
Seat material		PVC	PVC	Woven fabric	Woven fabric	Woven fabric
Radio with CD front loader		-	-	Standard	Standard	Standard
Slide Rear window		-	-	Standard	-	Standard
<b>EXTERIOR</b>						
Roll bar		-	-	Standard	-	Standard
Cab protector (guard frame)		Standard	Standard	-	Standard	-
Front bumper		Black	Black	Body colour	Black	Body colour
Rear bumper		Black tube type	Aluminium step type	Chrome step type	Aluminium step type	Chrome step type
Over fenders		-	Black	Body colour	Black	Body colour
Mud guards/flaps front		-	Standard	Standard	Standard	Standard
Mud guards/flaps rear		Standard	Standard	Standard	Standard	Standard
Side Steps		-	-	Standard	-	Standard
Roof rack/roof rail		-	-	Standard	-	Standard
Load box hooks/fastener		Outer hooks	Outer hooks	Smooth load bed, inner hook	Smooth load bed, inner hook	Smooth load bed, inner hook



**Nissan's commitment to the environment:** Nissan's environmental philosophy embraces people, vehicles and nature. In the pursuit of a sustainable mobile society, the Nissan Green Program aims to reduce the environmental impact of Nissan vehicles at every stage of the vehicle life cycle, while corporate activities address environmental challenges.

Every effort has been made to ensure that the content of this brochure is correct at the time of going to print (October 2019). This brochure has been produced featuring prototype or accessorized vehicles exhibited at motor shows and, in accordance with the company's policy of continuously improving its products, Nissan South Africa reserves the right to change the specification and the vehicles described and shown in this brochure at any time. Nissan dealers will be informed of any such modifications as quickly as possible. Please check with your local Nissan dealer to receive the most up-to-date information. Due to the limitations of the printing processes used, the colours shown in this brochure may differ slightly from the actual colours of the paint and interior trim materials used. All rights reserved. Reproduction in whole or part of this brochure without the written permission from Nissan is forbidden.



Nissan Intelligent Mobility moves you one step ahead. In cars that feel like an extension of you, helping you see more and sense more, reacting with you, and sometimes even for you. Nissan Intelligent Mobility is about a better future – moving us to a world that’s safer, more sustainable, and exciting.